

INSTALLATION TIPS

CARE + MAINTENANCE

Care must be taken to dry any spillage or leakage of water which may gain access to furniture. It is recommended that vanities are installed to avoid splashes from wet areas such as baths, spas and showers.

All wood composite veneers and polyurethane lacquer are water resistant only. To ensure the quality of finish is maintained, wipe up all spills with a clean lightly moistened cloth as soon as they occur. Use only a soft cloth, or a weak solution of non-abrasive detergent. Do not expose to excessive heat e.g. from hot hair styling equipment or naked flames.

To restore accidental scratches, burns etc. on two pack polyurethane parts or acrylic tops, rub gently with car cutting compound, car polish or household brass/silver cleaner.

To restore accidental scratches, burns etc. on veneer parts, paint with similar coloured wood restoration pens, let settle for one minute and wipe off excess with soft cloth.

WARRANTY INFORMATION

The Argent furniture warranty applies to Argent furniture only. The Argent Warranty is 5 years against manufacturing fault.

Finishes

All finishes are warranted against chipping and flaking, excluding normal wear and tear for five (5) years from date of purchase. Fading of colour due to excessive exposure to sunlight is excluded from the warranty.

Exclusions

This warranty is for normal domestic limited use only and excludes any defect or injury caused by or resulting from misuse, abuse or neglect, accidental damage, improper installation or other alterations or modifications which affect the reliability or performance of the unit that are not attributable to faulty manufacture.

For full Warranty information visit www.argentaust.com.au



Brisbane
Level 3 / 18 Wandoo Street
Fortitude Valley QLD 4006

Sydney
80 Abercrombie Street
Chippendale NSW 2008

Melbourne
206-208 Coventry Street
South Melbourne VIC 3205

Perth
Unit 1 / 40 Collingwood Street
Osborne Park WA 6017

Technical Advice
1300 356 717

Fax
1300 656 057

www.argentaust.com.au

STORE THIS DOCUMENT

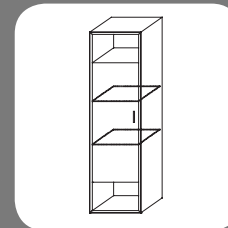

G10WO1601
G10WO1605
G10WO1606
Gallery Wall Hung

Gallery Wall Hung

INSTALLATION INSTRUCTIONS



INSPECT THE FURNITURE TO ENSURE NO DAMAGE HAS OCCURRED DURING TRANSIT. IF DAMAGE HAS OCCURRED, OR VISIBLE DEFECTS EXIST, DO NOT PROCEED WITH INSTALLATION AND ADVISE ARGENT IMMEDIATELY.

FURNITURE MUST BE FITTED THROUGH STUDS INTO THE WALL. USE FIXING BRACKETS PROVIDED.

IF STUD POSITIONING DOES NOT ALIGN WITH FIXING BRACKETS, CABINET MUST BE ADDITIONALLY SECURED THROUGH THE BACK BOARD TO STUDS. IF NO STUDS ARE FOUND TO SECURE THROUGH, NOGGINS MAY BE REQUIRED.

Split Batten

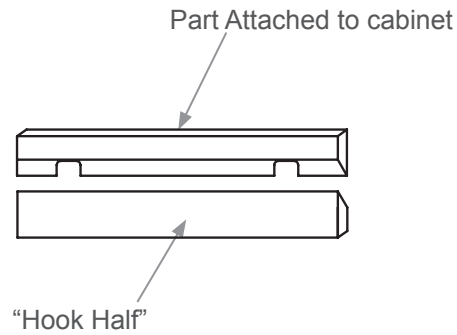

B

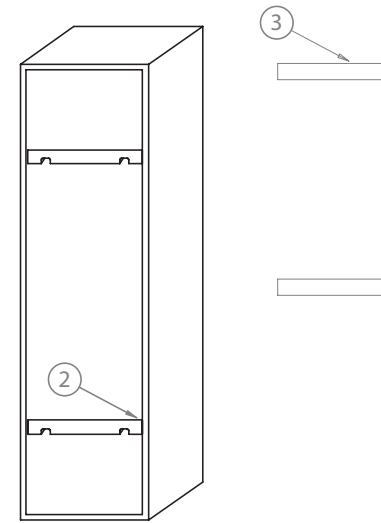

B MEASURE & MARK

Find in wall studs to secure to. Measure and mark where you are going to hang the "hook" side of the split batten **(3)**. Secure with appropriate fixing mechanism into the wall.

A PRIOR TO INSTALLATION

Argent recommends a qualified trade person fit your vanity. Ensure your furniture is installed to relevant building codes and Australian standards.

Please note, Argent will not be liable for the cost of installation or removal of the furniture and the warranty will be voided if damage occurred during or after installation.

Locate **(1)** split batten hanging bracket at rear of cabinet. Hold cabinet up at desired height to visually check intended hanging height. Note that there are two of **(2)** the split battens provided to be fitted according to whether you require a left or right swing door.

A

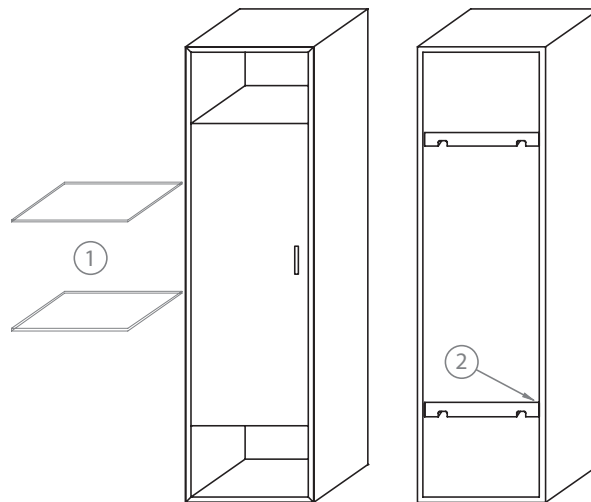

C

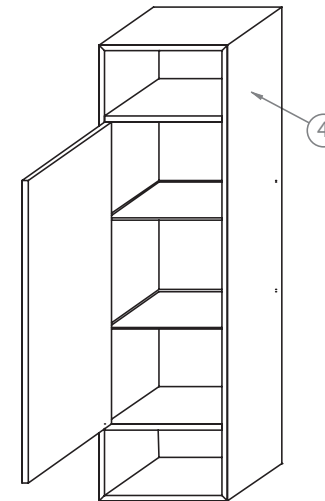

C FIT OFF & ADJUST

Lift cabinet up and over the secured "hook" part of the split batten, adjust to ensure the cabinet is level and secure **(4)**.

IMPORTANT:

INSPECT THE FURNITURE TO ENSURE NO DAMAGE HAS OCCURRED DURING TRANSIT. IF DAMAGE HAS OCCURRED, OR VISIBLE DEFECTS EXIST, DO NOT PROCEED WITH INSTALLATION AND ADVISE ARGENT IMMEDIATELY.