

Eurodisc

Contemporary Style

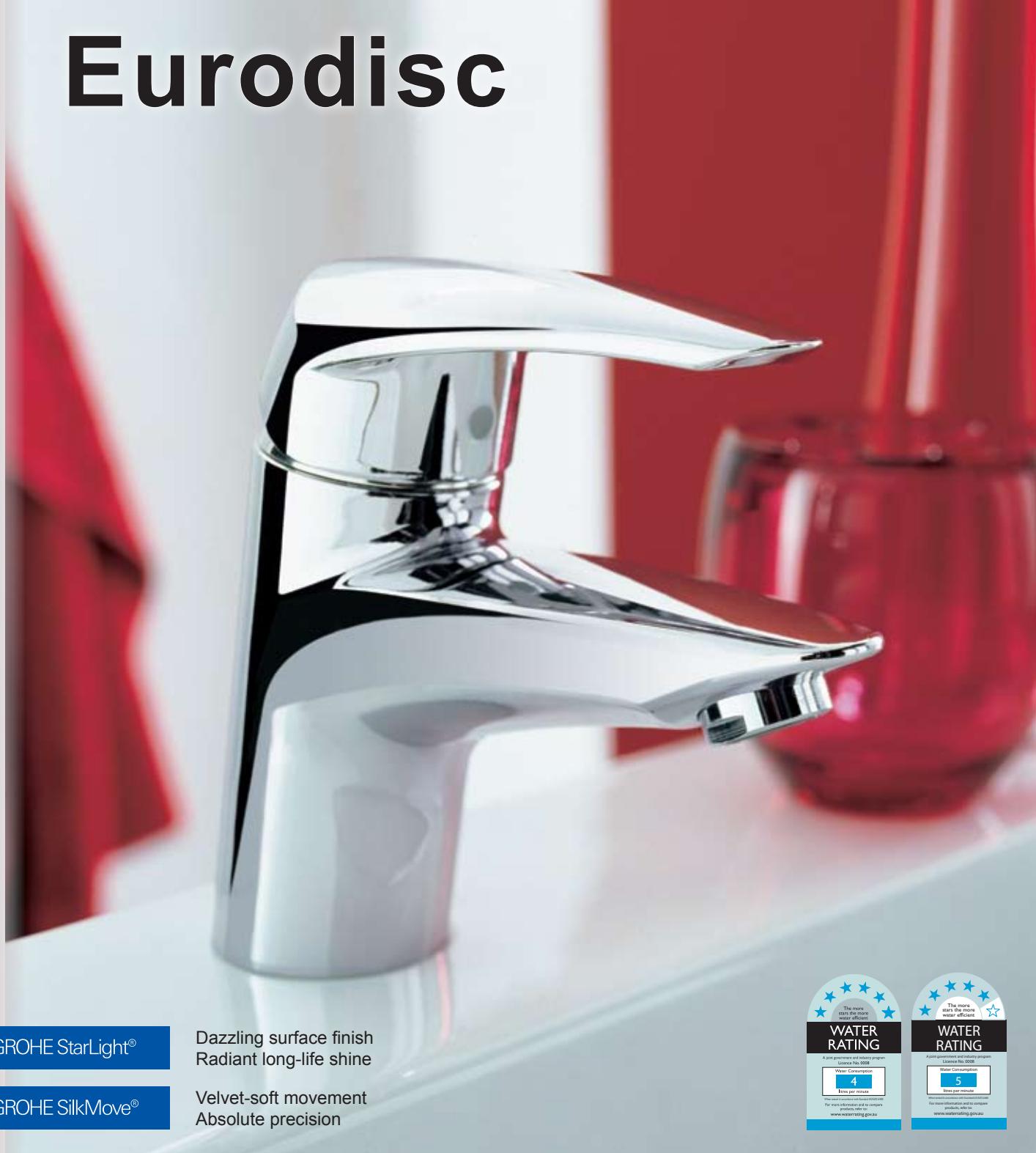

 GROHE StarLight®

Dazzling surface finish
Radiant long-life shine

 GROHE SilkMove®

Velvet-soft movement
Absolute precision



The new GROHE Eurodisc with GROHE SilkMove®

For a cool, self-confident bathroom, choose Grohe's new Eurodisc with its chic, sporty design and dynamic fin shaped lever. This visually striking product shouts style, distinction and self-assurance with. Its also packed with all of our latest technologies including GROHE SilkMove® for precise handling and GROHE StarLight® for a radiant, brilliant shine. With its top-end looks and features, the new Eurodisc is a professional choice - the smart way to banish uniformity in the bathroom.



GROHE®

ENJOY WATER

EURODISC Single Lever Basin Mixer
5 L/pm 5 star rating
4 L/pm 6 star rating

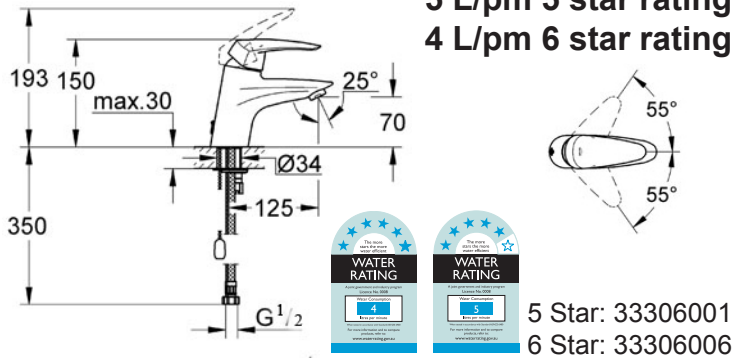

EURODISC Single Lever Bidet Mixer
with pop-up waste and swivel nozzle

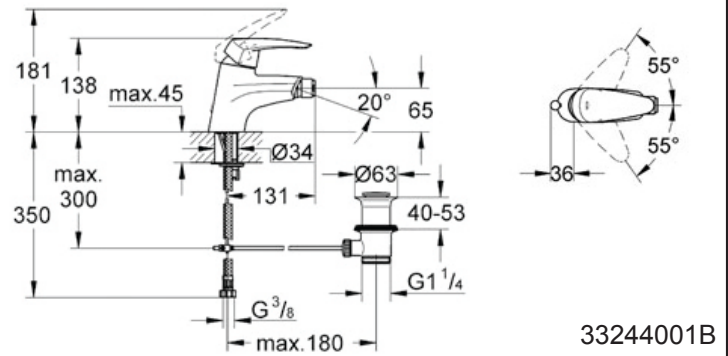

EURODISC Bath or Shower Diverter Mixer

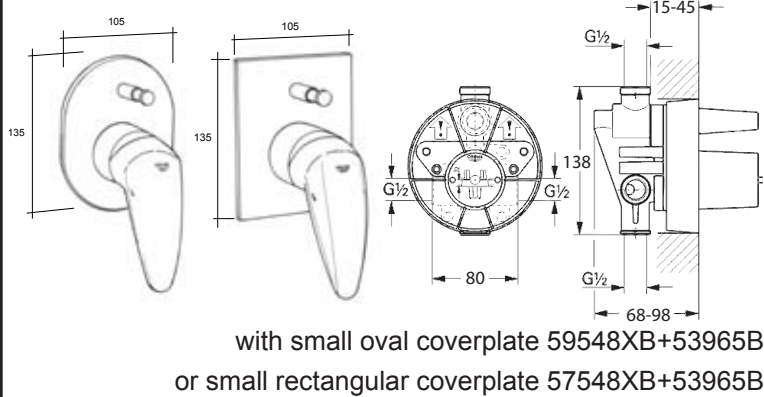

EURODISC Bath or Shower Diverter Mixer

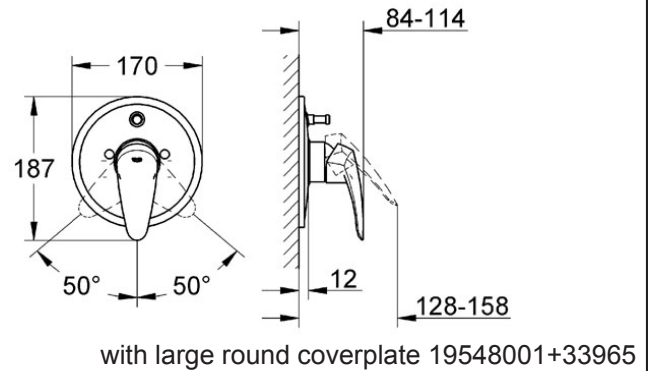

EURODISC Small Shower Mixer

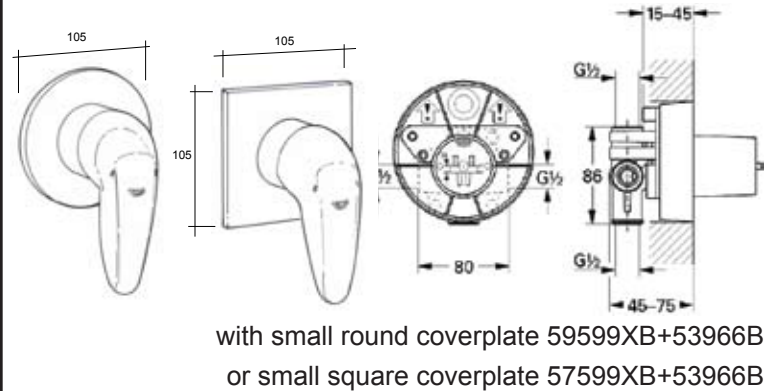

EURODISC Large Shower Mixer

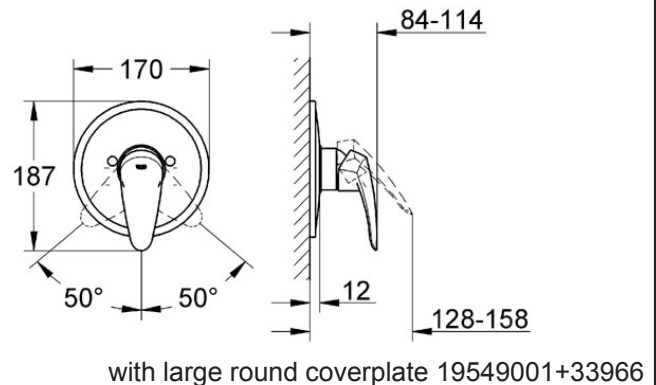

EURODISC Combination Mixer

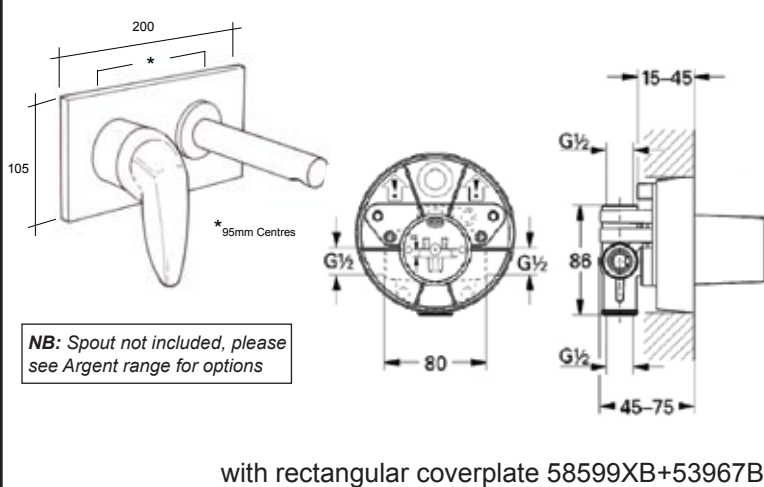

Brisbane

18 Wandoo St Fortitude Valley QLD 4006
 Ph: 07 3252 6101 Fax: 1300 656057

Melbourne

206-208 Coventry St South Melbourne VIC 3205
 Ph: 03 996 7661 Fax: 03 9696 7661

Sydney

80 Abercrombie St Chippendale NSW 2008
 Ph: 02 8394 5800 Fax: 02 8394 5888

Perth

Unit 1/40 Collingwood St Osborne Park WA 6017
 Ph: 08 9445 0500 Fax: 08 9445 0510

Argent Central

PO Box 2093 Fortitude Valley QLD 4006
 Ph: 1300 364 748 Fax: 1300 656 057

Technical Advice Hotline 1800 356 717

email: ac@argentaust.com.au

www.argentaust.com.au

