

# Pace 2.0 Diverter Mixer Trim

Brushed Gold

## Product Image



## Product Details

<b>Code:</b>	<b>D744285B</b>
Brand:	Argent
Range:	Pace 2.0
Warranty:	15 Years*
WELS:	N/A

## Additional Features

## Technical Specification

**Required Product**  
M515800

**Recommended Products**

**Additional Notes**

- 35mm Ceramic Cartridge
- Push Button Diverter Activation

**Installation Instructions**

\* ONLY COMPATIBLE WITH  
COLOURFLEX BODY M515800

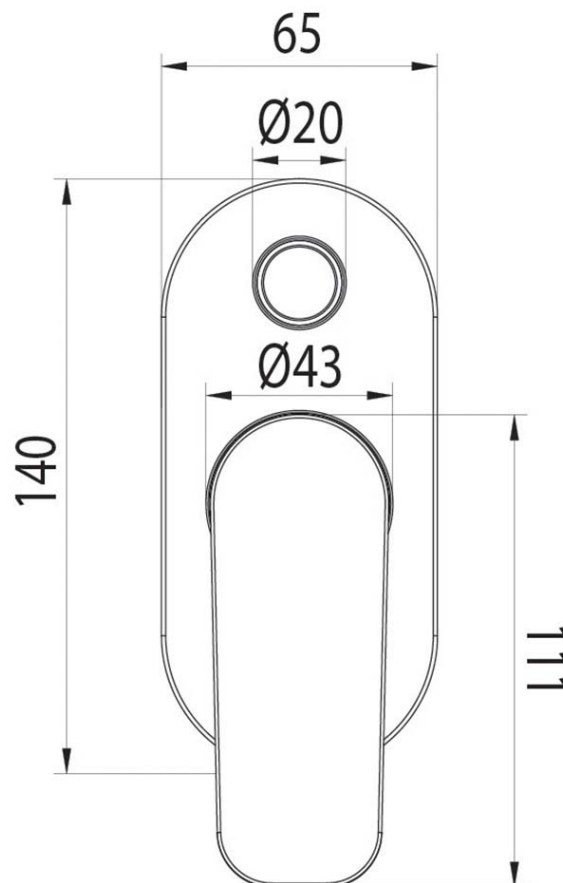

\*Please visit [argentaust.com.au/warranty](http://argentaust.com.au/warranty) to view the full warranty

Note: All dimensions are in millimetres and are subject to normal manufacturing variations. Always use the physical product measurements for cut-outs and rough-ins as the technical details shown may differ from the actual product. Use acetic cured silicone sealant. Do not use epoxy type adhesives. Clean with damp cloth. Do not use abrasive cleaners, liquids or pastes.

# ColourFlex Diverter Mixer body

## Product Image

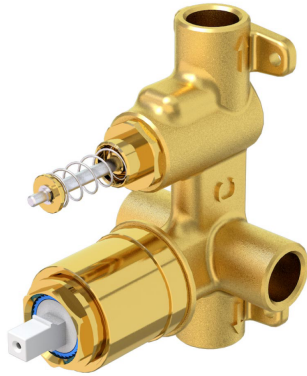

## Product Details

<b>Code:</b>	<b>M515800</b>
Brand:	Argent
Range:	ColourFlex
Warranty:	15 Years*
WELS:	N/A

## Additional Features

## Technical Specification

### Required Product

### Recommended Products

### Additional Notes

- Lead Free
- One Body For All Colours & Designs
- 4 Screw Fixing for Accurate Installation
- Compact Body

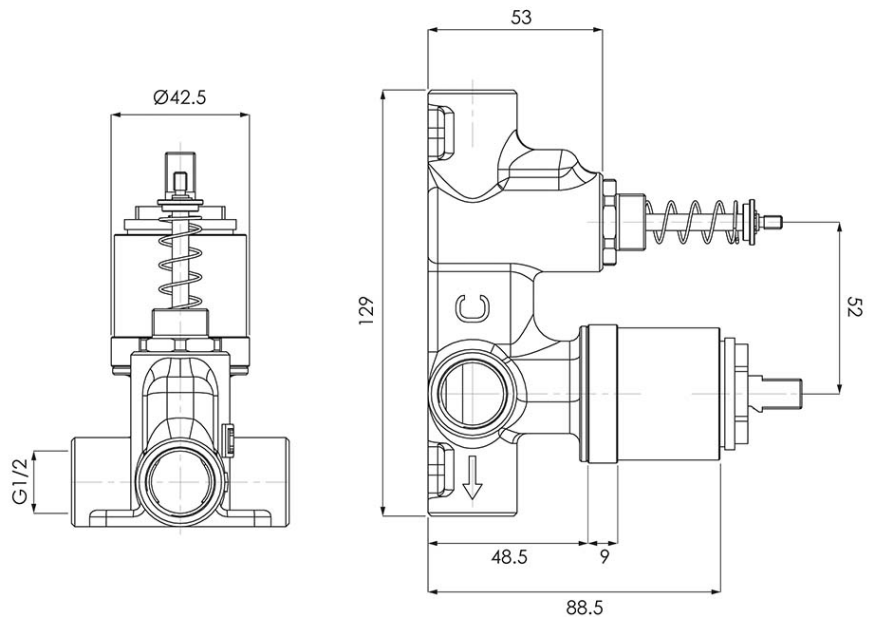

\*Please visit [argentaust.com.au/warranty](http://argentaust.com.au/warranty) to view the full warranty

Note: All dimensions are in millimetres and are subject to normal manufacturing variations. Always use the physical product measurements for cut-outs and rough-ins as the technical details shown may differ from the actual product. Use acetic cured silicone sealant. Do not use epoxy type adhesives. Clean with damp cloth. Do not use abrasive cleaners, liquids or pastes.