

Grace 2.0 Diverter Mixer Trim

Product Image



Product Details

Code:	D666361B
Brand:	Argent
Range:	Grace 2.0
Warranty:	15 Years*
WELS:	N/A

Additional Features

Required Product
M515800

Recommended Products

Additional Notes

- 35mm Ceramic Cartridge
- Push Button Diverter Activation

Installation Instructions

* ONLY COMPATIBLE WITH
COLOURFLEX BODY M515800

Technical Specification

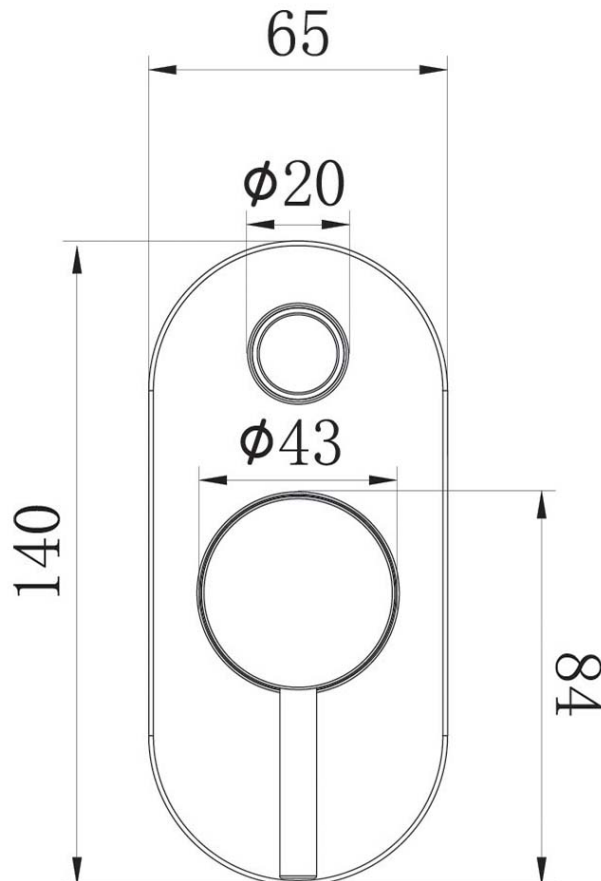

*Please visit argentaust.com.au/warranty to view the full warranty

Note: All dimensions are in millimetres and are subject to normal manufacturing variations. Always use the physical product measurements for cut-outs and rough-ins as the technical details shown may differ from the actual product. Use acetic cured silicone sealant. Do not use epoxy type adhesives. Clean with damp cloth. Do not use abrasive cleaners, liquids or pastes.

ColourFlex Diverter Mixer body

Product Image

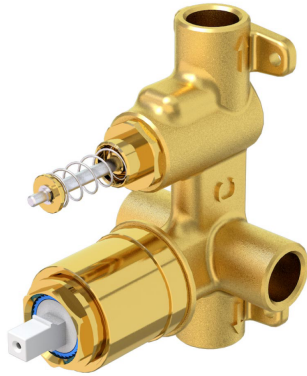

Product Details

Code:	M515800
Brand:	Argent
Range:	ColourFlex
Warranty:	15 Years*
WELS:	N/A

Additional Features

Technical Specification

Required Product

Recommended Products

Additional Notes

- Lead Free
- One Body For All Colours & Designs
- 4 Screw Fixing for Accurate Installation
- Compact Body

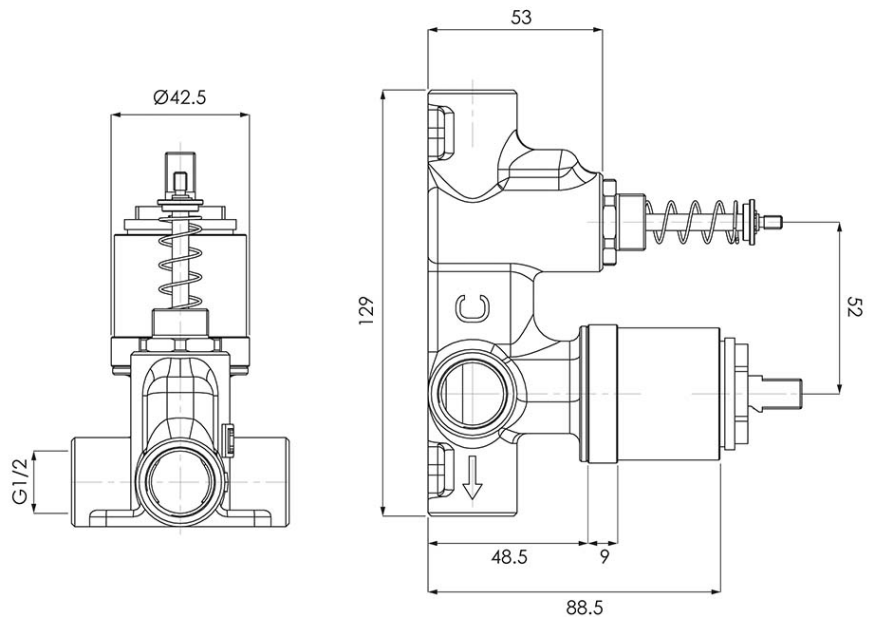

*Please visit argentaust.com.au/warranty to view the full warranty

Note: All dimensions are in millimetres and are subject to normal manufacturing variations. Always use the physical product measurements for cut-outs and rough-ins as the technical details shown may differ from the actual product. Use acetic cured silicone sealant. Do not use epoxy type adhesives. Clean with damp cloth. Do not use abrasive cleaners, liquids or pastes.