



Pace Comfort 170 Diverter Trim

Brushed Nickel

Product Image



Product Details

SKU:	DL332625BN
Brand:	Argent
Range:	Pace Comfort
Warranty:	15 Years
WELS:	N/A

Additional Features

Technical Specification

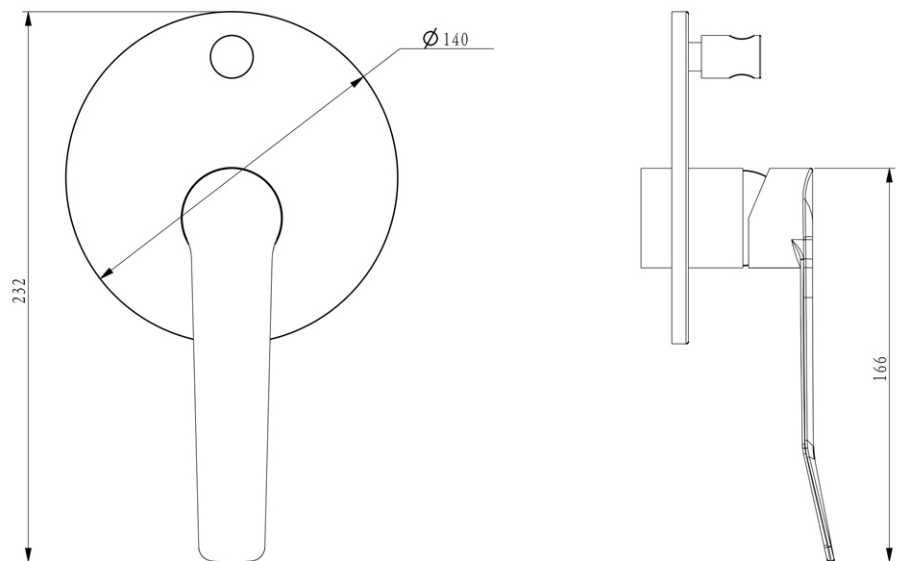

Note: All dimensions are in millimetres and are subject to normal manufacturing variations. Always use the physical product measurements for cut-outs and rough-ins as the technical details shown may differ from the actual product. Use acetic cured silicone sealant. Do not use epoxy type adhesives. Clean with damp cloth. Do not use abrasive cleaners, liquids or pastes.