

Instruction manual

Wall Faced Smart Toilet System

comprising

AF421001S4B Smart Toilet &
IN38905 WB Matching Smart Cistern

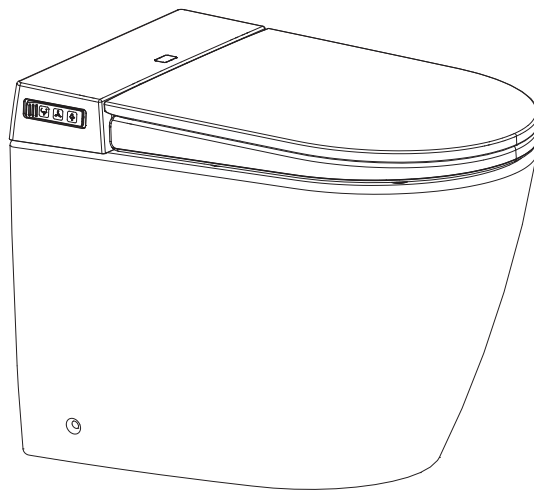

IMPORTANT:

Installation is subject to the requirements of the applicable regulatory authority, the National Construction Code Volume Three -Plumbing Code of Australia, associated reference standards as applicable at the time and AS/NZS 3500. bidet douche seat includes air-gap assessed and found to comply with the requirements of as 2845.2:2010. no further backflow prevention is required for this connection to water supply.

To install, tighten each inlet connection to 10 N.m Max. torque.
Leakage test shall be done before first use. Only qualified Tradespeople should be used for
Installation and maintenance.

Water temperature: 4-35° C

Only watermark certified components should be used to match with these Smart Toilets .

NOTES FOR INSTALLATION

1. PLEASE ENSURE PIPEWORK IS FLUSHED CLEAR OF DEBRIS BEFORE CONNECTING SUPPLY PIPES TO THE CISTERN AND WASH
2. INLET PRESSURE RANGE 100 – 500KPA
3. AS/NZS 3500 REQUIRES 500 KPA MAXIMUM OPERATING PRESSURE AT ANY OUTLET WITHIN A BUILDING
4. NOT SUITABLE TO BE INSTALLED WITH A GRAVITY FEED SYSTEM
5. MATCHING CISTERN IN38905 (WB)

※ Please read this manual thoroughly before using the product.

※ Please do not hesitate to contact us if you have any questions in the installation or usage.

※ Please safekeeping this manual after reading.

Contents

Safety precautions	1
Bill of material	4
Specification	5
Parts name	6
Installation Tools	7
Product installation	8
Introduction for remote control panel	11
Instructions for remote control Installation	12
Instruction	13
Side push button instruction	14
Cleaning	15
Common troubles and shooting	16
Maintenance Service Sheet	18
Maintenance record	19



Safety precautions



In order to avoid injury and property loss, please follow the safety warnings and precautions. Read this manual carefully before installation, and then install it accordance with the instructions. After you have finished reading, please keep the instructions for the end user.



 **WARNING** It means that if you ignore this sign It may cause personal injury or property damage

 Below items are prohibited

 These are compulsory requirements

 WARNING	
	Make sure that this product is correctly attached to a grounded connection. (If the product is not grounded, it may introduce the risk of electric shock)
	Please do not use a loose power connection, or it may cause electric shock or cause fire.
	Please do not spray detergent, water, cleaning agent in or around the power supply, this may cause electric shock or fire.
	Always use the specified supply voltage (240VAC, 50Hz), it is necessary to install a circuit breaker, exclusively devoted to the Evo washlet.
	Prior to the installation, a suitable electrical connection should be available, according to the current local legislation.
	Rainwater, demineralized water, sea water or grey water are not suitable to operate this equipment. Operate with normal drinking water only.
	Recommended water pressure is between 100–500Kpa Recommended water temperature is between 4–35° C
	Use only mild detergent and a soft cleaning cloth for cleaning the seat and surrounding pan, (Enjo or similar micro fibre cleaning products are suitable) Typical toilet cleaning procedures for inside pan are suitable. Bleach or chlorine-based products should not be left inside the pan with the seat shut or for prolonged periods.
	Standing on the seat, using the seat for a plank or any use outside of a typical weight not evenly distributed can cause damage to the seat and will void the warranty. The washlet must be installed by recognized professional tradespeople. i.e. Plumber and Electricians.
	Use only Watermark approved flexible hoses for this installation.
	Do not attempt to disassemble and/or repair the product without authorization, any work by non-professionals will void the warranty and may cause damage to the product.

 WARNING	
	<p>Please stop using if the seat cover malfunctions Please cut off the power supply, and close the water-inflow valve to stop water supply if following cases happen:</p>
	<p>Faults: Excessive heating; smoking; Abnormal sound and odour; Products cracks, damages; or blocked.</p> <p>It may cause electric shock, injury, fire or indoor problems if you continue to use it when it is malfunctioning.</p>
	<p>Please do not use gasoline, detergent, nylon brush and other non-neutral cleaning agent to clean the seat cover and other plastic parts. Otherwise, it may cause a chemical reaction or crack, which will lead to injuries.</p>

 WARNING	
	<p>Make sure the power supply is cut off when the product is maintained, or it may cause an electric shock or fire.</p>
	<p>Please make sure that the power is correctly connected to the AC 220V/50Hz power socket, or it may cause electric shock or fire. must have an isolated circuit breaker.</p>
	<p>Please turn off power before taking out washlet seat or it may cause electric shock.</p>
	<p>Please ensure the bathroom is ventilated to make sure the atmosphere is suitable, as the washlet is an electric appliance product, please do not install in the place with high moisture or somewhere easy to get wet. Otherwise, it may cause electric shock or fire.</p>
	<p>Please close the water-inflow valve if water leakage, and ask the professional person to repair it, or it may lead the damage of products.</p>

 **WARNING**



Please turn off inlet valves , drain water out from toilet and cut the power when not using products for a long time . Please through the water when you use this product again , to prevent water quality problems , which will cause skin diseases . Otherwise , it may cause electric shock , injury or fire.

Please tighten each waterway connection when installing it or it may cause water leakage.

Please pay attention to socket and installation position.
Please set the leakage protector in the socket circuit or insulation transformer(1.5KVA–3KVA).
Power socket installation location should at least 0.5 m above the floor, and keep away from objects out of water such as shower and bathtub. Otherwise it may cause water leakage.

Please turn off power before cleaning products and do not clean products with water directly or it may cause electric shock or fire.

Please put the product in the shade or the products may fade or burnt on the surface.

Please increase indoor temperature and make sure the water is flowable before using to avoid damage in cold region, or it may cause products damaged or water leakage.

To prevent scalding users, the seat temperature will decrease automatically after seated 15mins.

Please make sure the power supply and inlet valves are turned off before taking caver off the seat, or it may cause electric shock or fire.

This appliance can be used by children aged from 8 years and above and persons with reduced physical, sensory or mental capabilities or lack of experience and knowledge if they have been given supervision or instruction concerning use of the appliance in a safe way and understand the hazards involved.

Children shall not play with the appliance.

Cleaning and user maintenance shall not be made by children without supervision.

The appliance is not to be used by persons (including children) with reduced physical, sensory or mental capabilities, or lack of experience and knowledge, unless they have been given supervision or instruction.

If the supply cord is damaged, it must be replaced by the manufacturer. its service agent or similarly qualified persons in order to avoid a hazard.

Bill of material

Ceramic Pan and seat

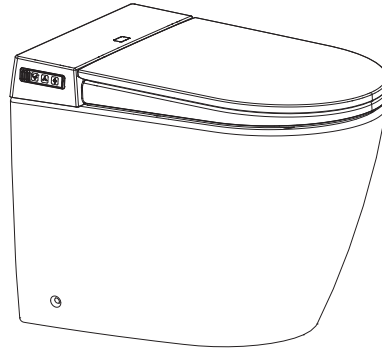

REMOTE CONTROL

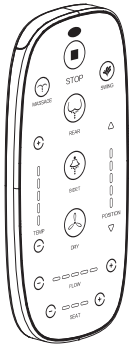

REMOTE EXPANSION
SCREW GROUP
(EACH 2 PCS)

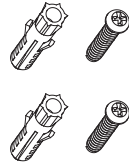

REMOTE CONTROL
HOLDER

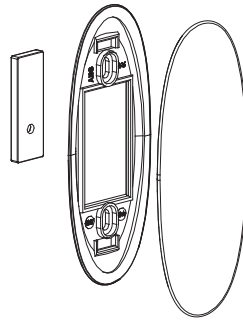

AAA
BATTERY*2
(NOT INCLUDED)

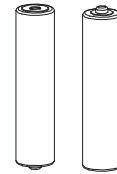

DOUBLE SIDE
TAPE



INSTRUCTIONS

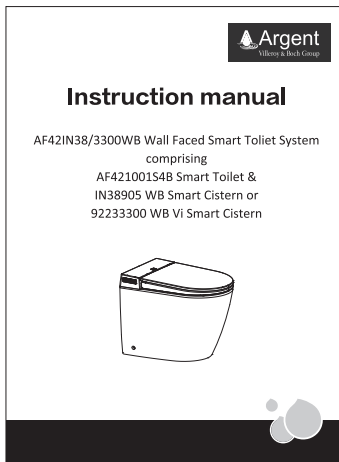

TFF--II INCTION

(2 PCS)



NOZZLE
(1 PCS)

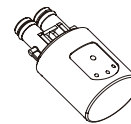

CERAMIC FIXED
COMPONENTS
(EACH 2 PCS)

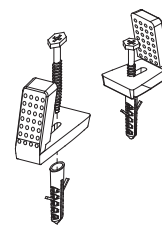

INLET HOSE (1 PCS)
WM 050002

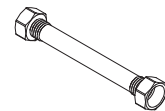

ADJUSTABLE
VARIO BEND
(WMK25968)

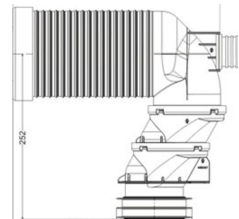

Specification

Model: AF421001SB

The rated power		220V~ 50Hz	
Water temperature range		About 35°C~42°C	
Drying temperature control		About 32°C~57°C	
Surface temperature		Room temperature~About 42°C	
Deodorizer		Catalyst deodorizing	
Soft-close control for seat cover		Slow dropping mechanism	
Cleaning water consumption		4.5L/3.0L	
Washing method		Flush type	
Rated power	1100W	Maximum power	1600W
Temperature of supplied-water	4°C~35°C	Ambient temperature	3°C~40°C
Waterproofing grade	IPX4	Product size	592*400*492mm
Pressure of supplied-water	0.1MPa (Dynamic pres-sure) ~0.5MPa (Static pressure)		

And under the condition of 15°C ± 1°C water-inflow temperature, heighten the water quantity, the seat temperature and the water temperature in turn, to start the feminine cleaning in an average power.

- ※2: Maximum power: water pressure is 0.18MPa + 0.02MPa under the ambient temperature of 23°C ± 2°C. And under the condition of 15°C ± 1°C water-inflow temperature, heighten the water quantity, the seat temperature and the water temperature in turn, to start the feminine cleaning in an average power.

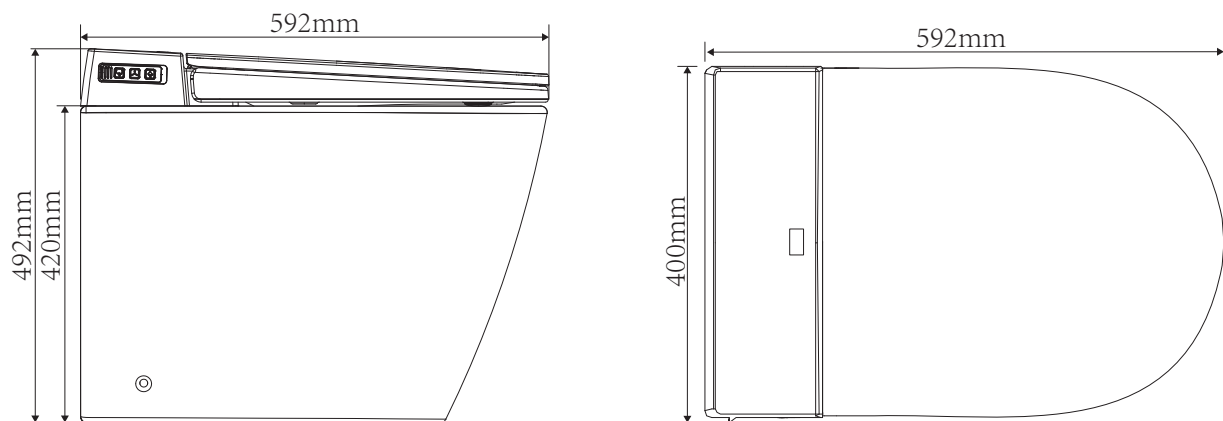

Parts name

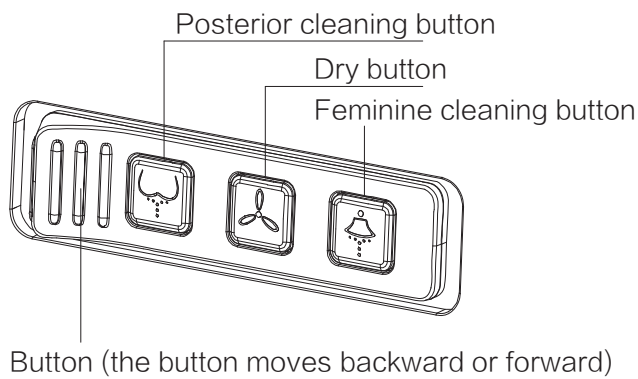
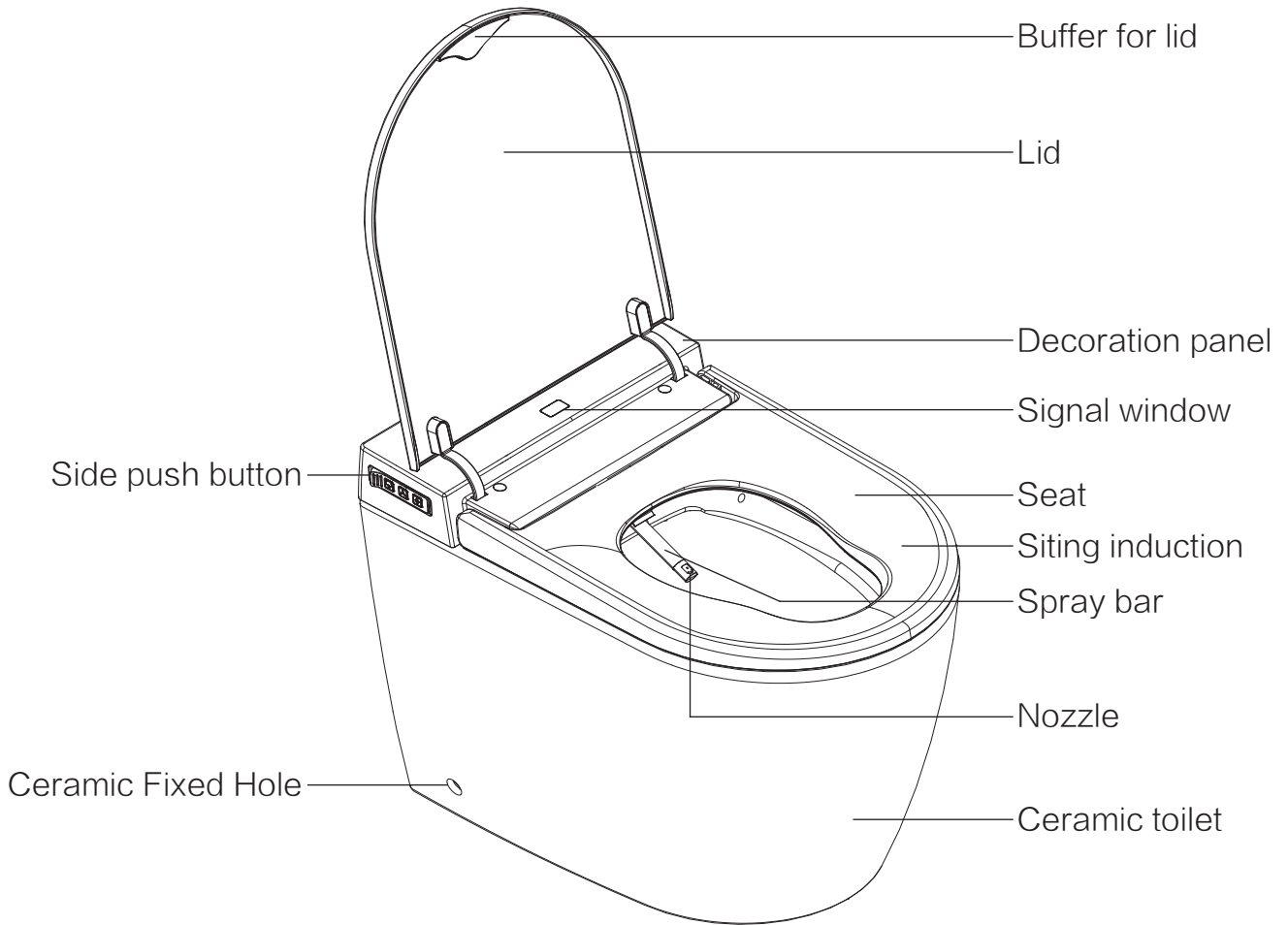

Installation Tools

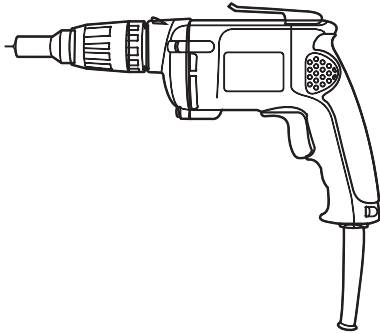

Percussion Drill

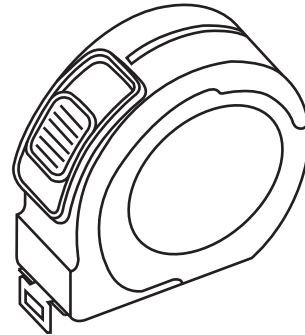

Tape

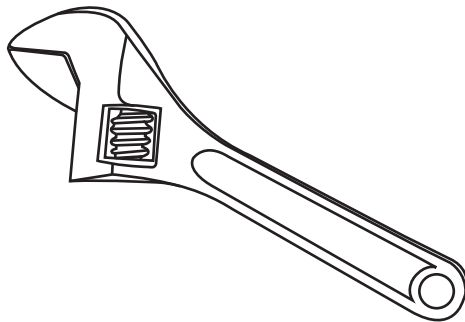

Adjustable Wrench

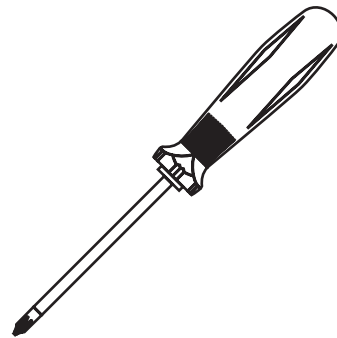

Screwdriver

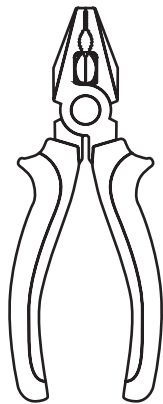

Pliers

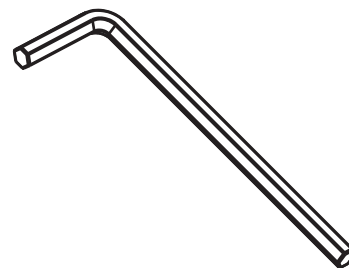

Inner hexagon spanner

Product installation

1. Fix the water tank and then connect the water supply to the cistern tank.

MATCHING CISTERN IN38905 (WB)

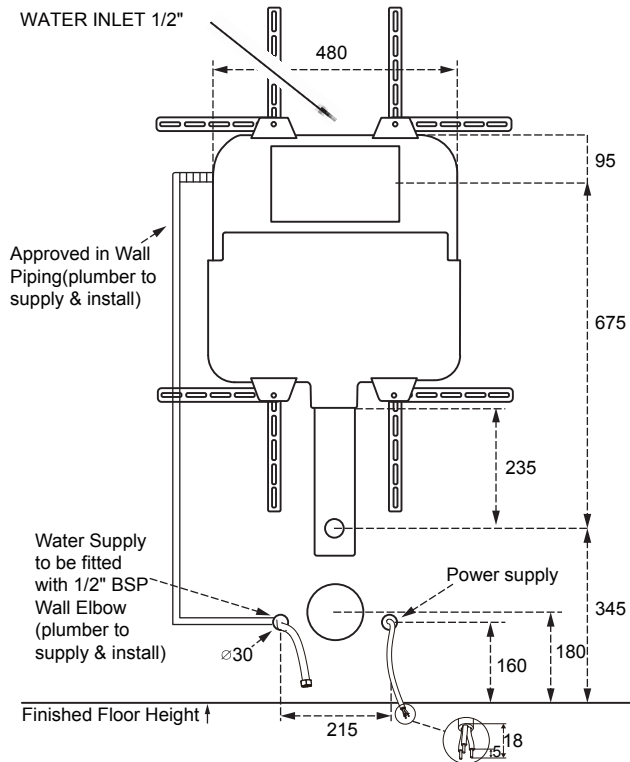

92233300 (WB)

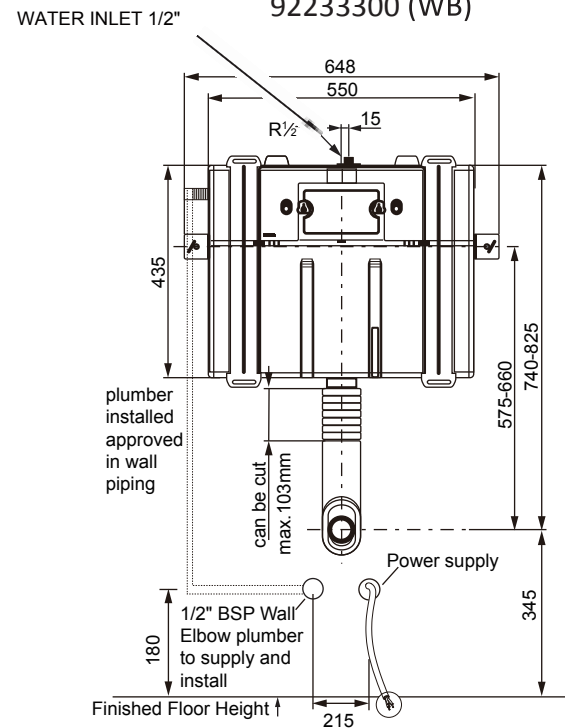

2. Connect the 1/2" thread in the side of the cistern to a 1/2" BSP wall elbow at the rough in position for the washlet water supply.

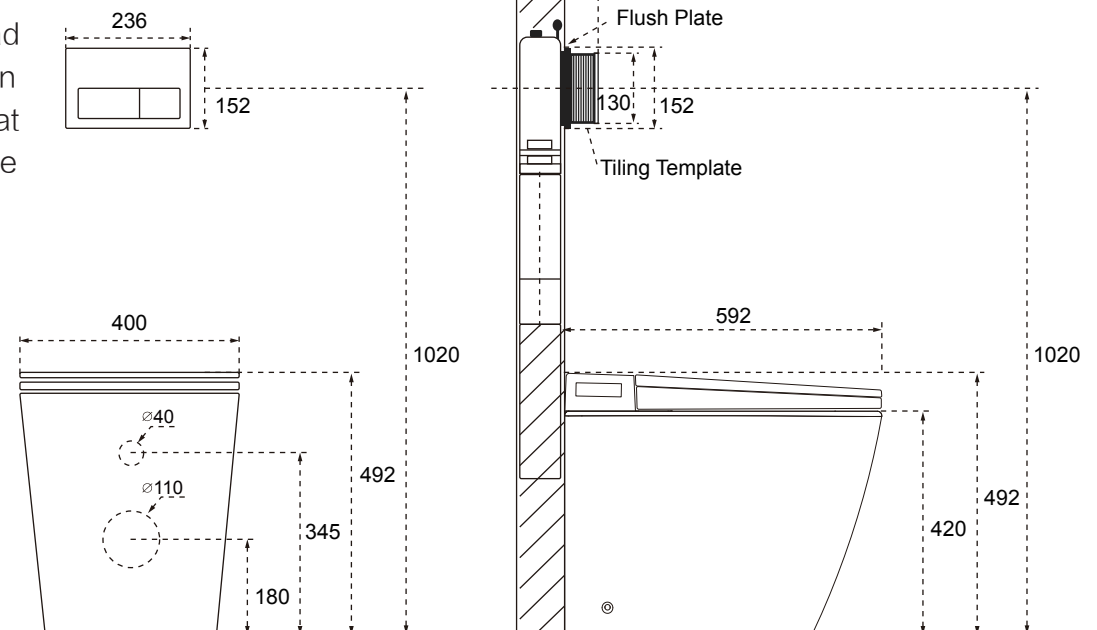

Product installation

3. Open the lid and use a tool to remove the decorative screw caps (A new pair is in the spare part box).
Use screwdriver to undo the screws.
Take out the electronic seat and cover and put them in a clean place.

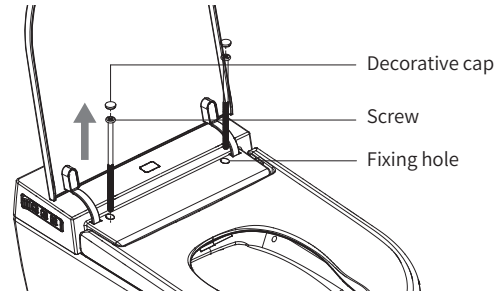

4. Take out the drain pipe fitting, and select the appropriate drain pipe fitting according to the actual pit distance L of the drain pipe.

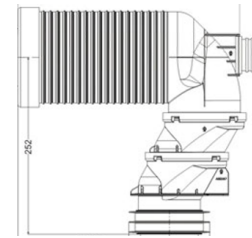
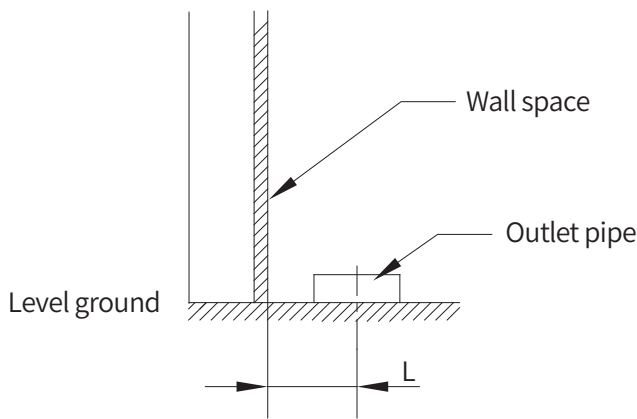

(L=95-115)

5. Match the length of the sewage pipe with the ceramic, and cut the excess pipe length.

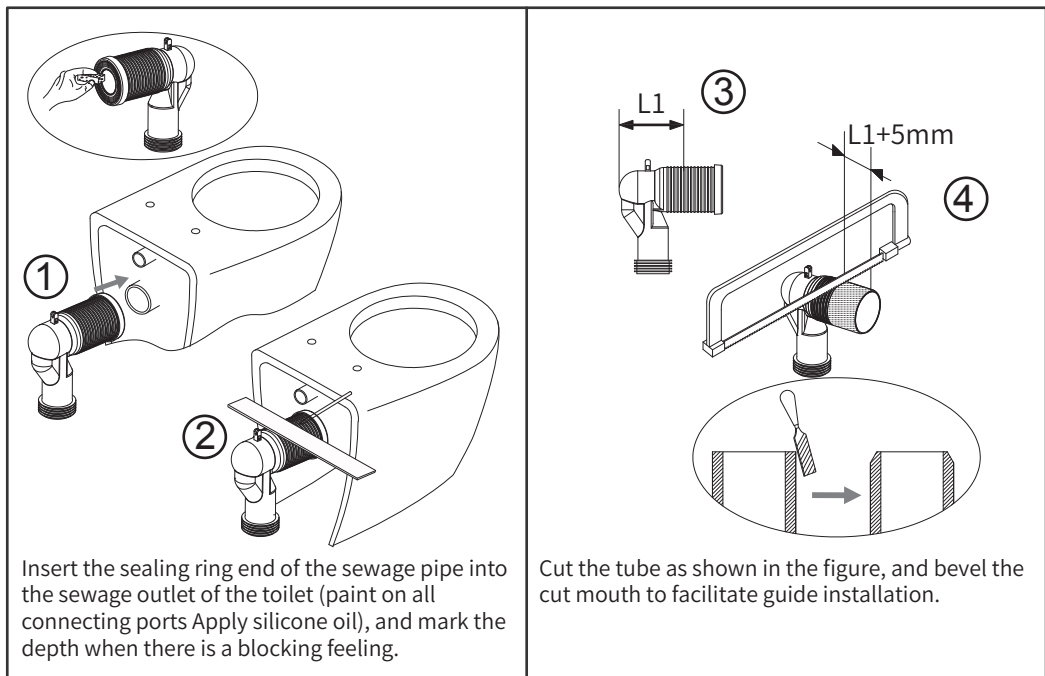

Product installation

6. Install the drain pipe fitting group according to the size and height shown in the figure, and fix it with the wall with bolts

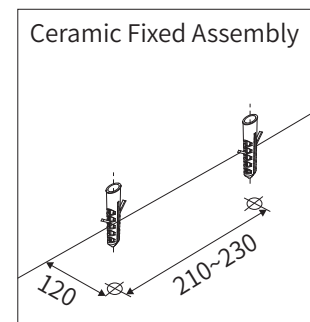
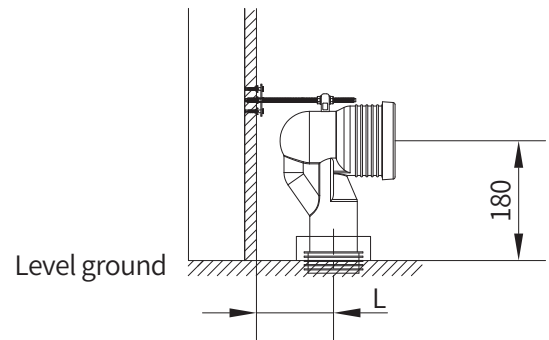
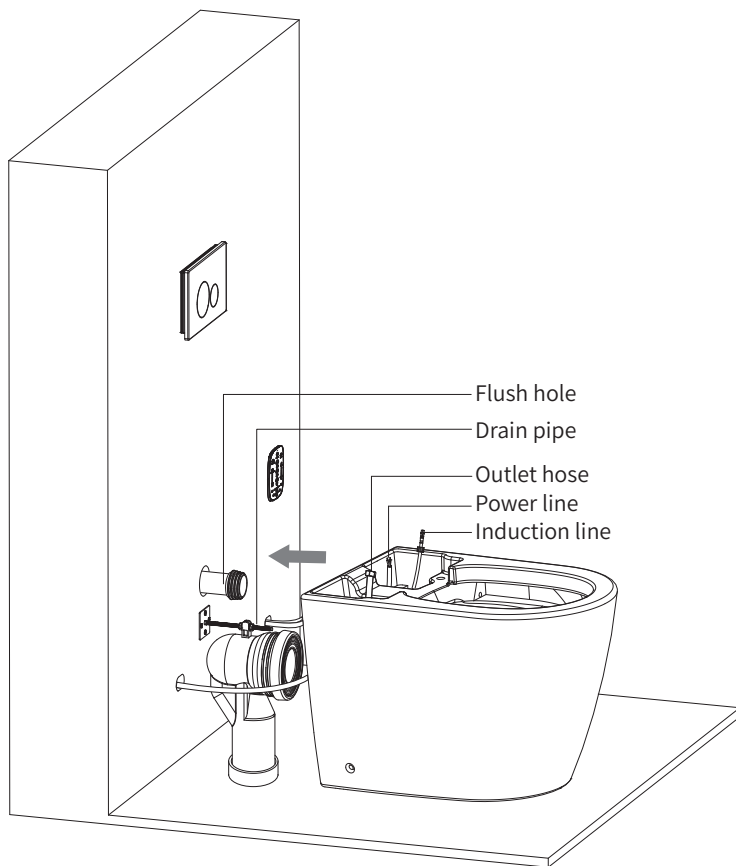

7. Firstly, punch two holes on the floor as shown above, and then fix the plastic expansion pipe to the floor.

The outlet pipe and power cord penetrate into the toilet from the back of the toilet. The flushing holes and drainage holes of the toilet are aligned to the corresponding position, and the toilet moves slowly to the arrow direction and sticks to the wall.

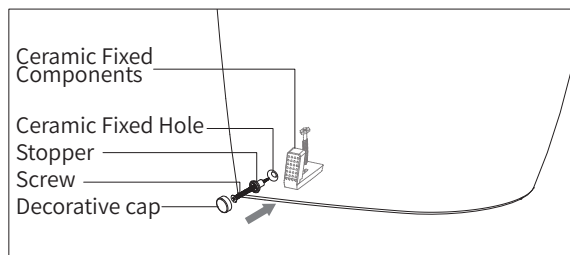

8. Put the ceramic fixed components into the ceramic O-shaped hole, lock the small screws and fixing plugs with the ceramic fixed components from the ceramic side, then lock the large fastening screws with the reserved holes on the ground from the ceramic side, and finally the decorative cap is put on the back sleeve.

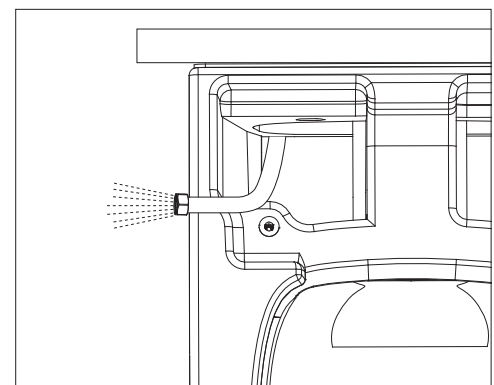

9. The toilet is fixed and then drained.

Product installation

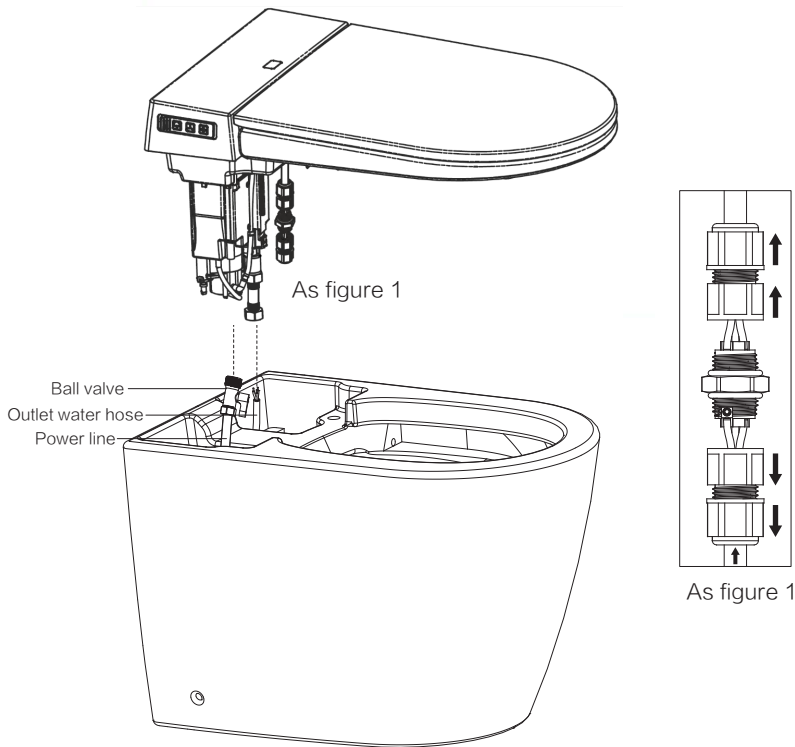

6. Attach outlet water hose and power line to toilet as the arrow shows in figure.

7. Put the toilet seats set on the top of ceramic body and then open the upper cover, fastened by fixing screw and then put the decoration cap.

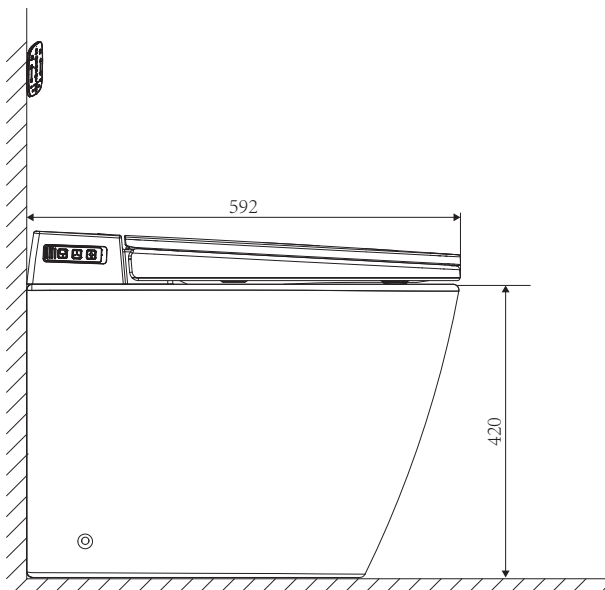
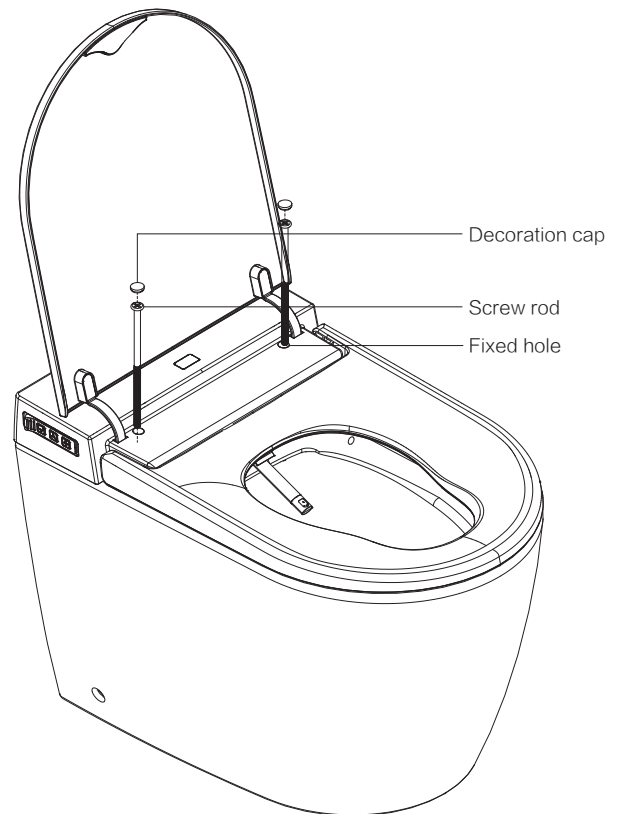

8. When the installation is completed, the remote control is installed in an appropriate position and is placed near the toilet for easy access.

Instructions for remote control Installation

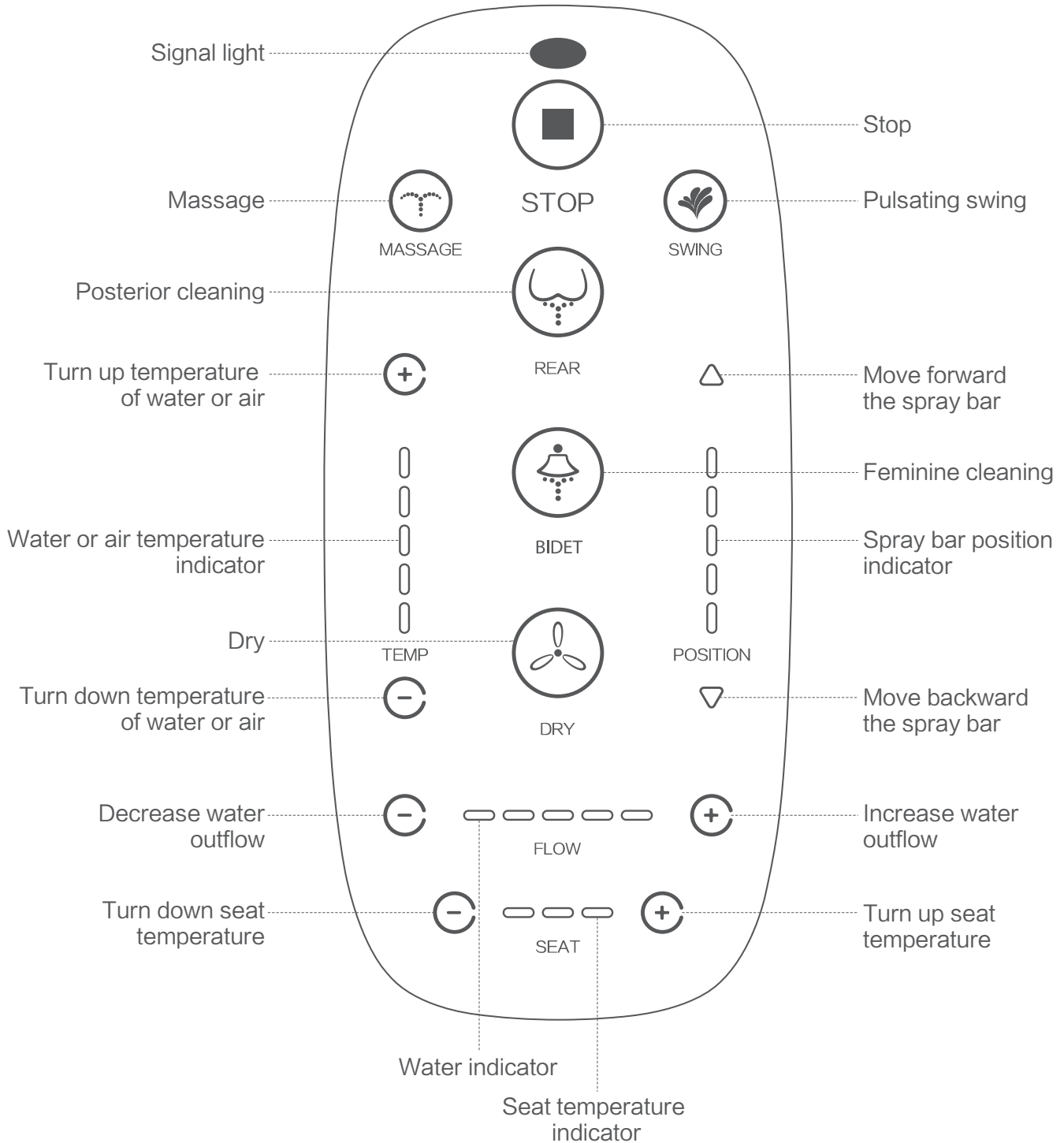

Instructions for remote control Installation

Method 1: ①. Install the remote controller fixing panel with a magnet on the remote control fixed seat and lock tightly

Note: Pay attention to the polarity when installing the magnet. Place the larger side of the magnet hole outside the fixed panel and enclose the small hole surface inside the fixed panel; as shown in the below figure 1;

②. Put the double sided tape on the remote control fixed seat;

③. Clean dust, grease, water droplets on the walls and wipe them clean;

④. Press the remote control fixed seat with double sided tape on it, Press it evenly for 3 to 5 min Utes. Attach the remote control fixed seat to the wall;

Note: The method is applicable to glazed tiles, glass and smooth wall

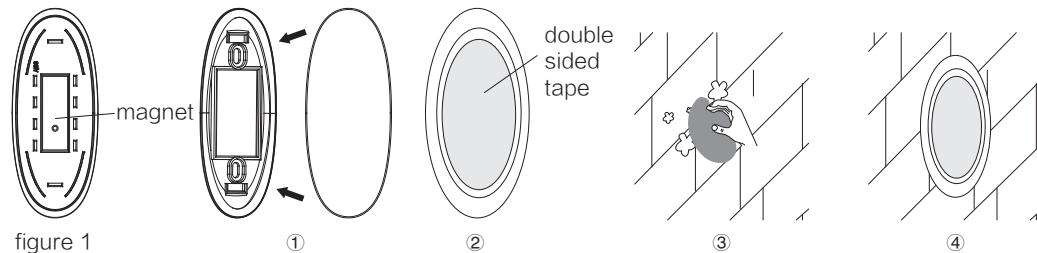

Method 2: ①. Drill a hole of 46mm–52mm length and 22mm depth on the wall by the drill with the diameter of 6mm

Note: the position of the hole shall be satisfied when the person is seated on the seat cover. It is convenient for the user to catch the remote control;

②. After installing the expansion plug in the wall align the fixing hole of the remote controller at the expansion plug and then locking the bolt. Install the remote controller fixing panel with a magnet on the remote control fixed seat and lock tightly

Note: pay attention to the polarity when installing the magnet. Place the larger side of the magnet hole outside the fixed panel and enclose the small hole surface inside the fixed panel; as shown in the below figure 2

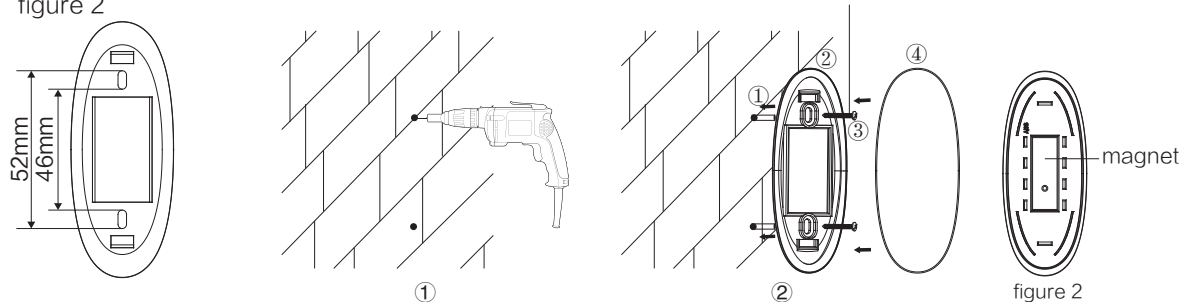

Put the remote controller on the fixed base after installing the battery, and the remote controller can automatically absorb on the fixed base.

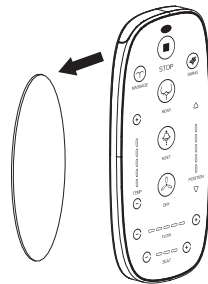

Note: ※ Please place the remote on the fixed place if not use. (To avoid the remote falling down)

※ It may cause damage if the remote controller falls down.

※ Please do not spill water on the remote control or drop into the water, or it may cause damage.

Instruction

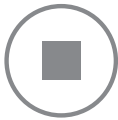

Stop

- ※ Press the button, all functions off.
- ※ The way to switch the atmosphere lamp is to hold the STOP button



Posterior cleaning

- ※ Press the button, rear function on after beep sounds, auto off after 2 mins or off by pressing the stop button.
- ※ Function will stop immediately if user leaves.



Feminine cleaning

- ※ Press the button, bidet function on after beep sounds, auto off after 2 mins or off by pressing the stop button.
- ※ Function will stop immediately if user leaves.



Dry

- ※ Press the button, dry function on after beep sounds, auto off after 2 mins or off by pressing the stop button.
- ※ Function will stop immediately if user leaves.



Massage

- ※ Under posterior/feminine cleaning mode, per press the massage button, the working mode can be changed and settings;
- ※ Interval massage mode: nozzle will expel the water to clean under different pressures;
- ※ Powerful massage mode: nozzle will expel the water to clean under different pressures;

Massage working mode:

No massage–Interval massage– Powerful massage– No massage is a circulate



Swing

- ※ Under posterior/feminine cleaning mode, press swing button, start to move cleaning mode, nozzle moving cleaning back and forth, press swing button again, stop move cleaning, waiting the posterior/feminine cleaning mode stop or press stop button to stop work.



Water temperature settings

- ※ Under rear mode or bidet mode, the initial setting is 3, press plus button will increase the water temperature, press minus button will decrease the water temperature. Total 5 settings, and corresponding indicator will on under different settings.

Air temperature settings

- ※ Under dry mode, the initial setting is 3, press plus button will increase the air temperature, press minus button will decrease the air temperature. Total 5 settings, and corresponding indicator will on under different settings.



Spray position adjusting

- ※ Under Posterior and feminine mode, the initial setting is 3, press plus button will forward the spray position, press minus button will backward the spray position. Total 5 settings, and corresponding indicator will on under different settings.



Flow adjusting

※ Under rear mode or bidet mode, press plus button will increase the water flow, press minus button will decrease the water flow. Total 5 settings, and corresponding indicator will on under different setting.



Seat temperature adjusting

※ Seat heated after seated, press plus button will increase seat temperature, press minus button will decrease seat temperature. Total 3 settings, and corresponding indicator will on under different setting.

Side push button instruction

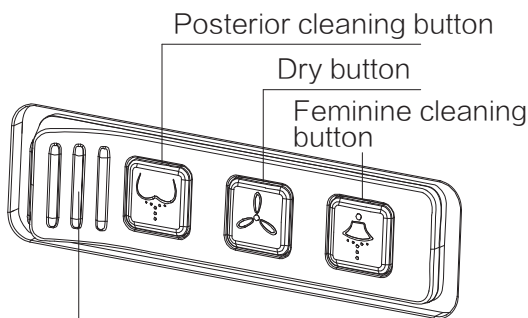

Button (the button moves backward or forward)

※ To activate or stop the beep sound:
In the non-seated state, push the side button back for more than 5 seconds to activate or stop the beep.

Posterior & Feminine cleaning function show:

Function 1: Press posterior/feminine cleaning button to start clean hip/women's private parts.

Function 2: Under posterior/feminine cleaning mode, press relevant button again to stop cleaning.

Function 3: Hold down posterior/feminine cleaning button to be run below mode:

Posterior/feminine cleaning → massage cleaning → dry → stop
※ Remark: Users can turn on/off the night light function when not seating on the toilet.

Dry function show:

Function 1: Press the dry button to start dry the moist parts with warm air.

Function 2: Under dry mode, press the dry button to stop drying.

Push button function show:

Function 1: Under posterior/feminine cleaning mode, push forward the side button to adjust the position of the nozzle ;(default setting is 3, total 5 settings)

Function 2: Under posterior/feminine cleaning mode, push forward the side button to adjust volume of water;(default setting is 3, total 5 settings)

※ Remark: The way to switch the above two functions is to hold the dry button more than 2 seconds, the function switch successfully after it sounded "Di".

Function 3: Under the dry mode, push forward the side button to adjust temperature; (default setting is 3, total 5 settings)

Night Light: On / Off

To activate or de-activate the 'night light: In non-seated state, push and hold the Posterior cleaning button for 5 seconds.

Cleaning

Lid and seat cleaning

- 1、 Turn off the power and water inlet valves.
- 2、 Wipe the lid and seats by sponge or smooth cloth with soap or mild detergent.
- 3、 Turn on the power and water inlet valves

Ceramic body cleaning

- 1、 Cut the power supply plug off.
- 2、 Clean the ceramic body by toilet brush with specified detergent.
- 3、 Plug in and press the flush button to wash away the detergent.

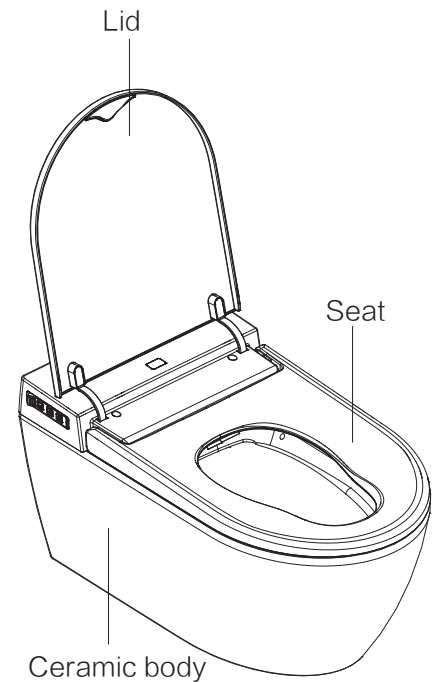

Nozzle cleaning

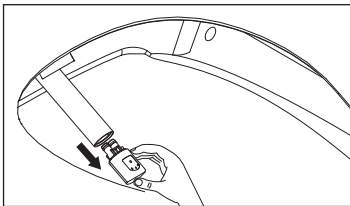

- ① Press the posterior-cleaning button & bidet button after 2 second to make the nozzle extends out of the machine, then remove the nozzle.

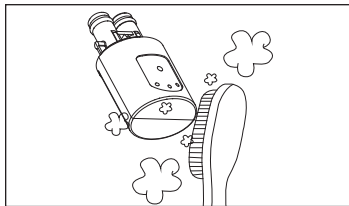

- ② Wipe the nozzle and spray rod by the toothbrush, sponge, or smooth cloth with soap or mild detergent.

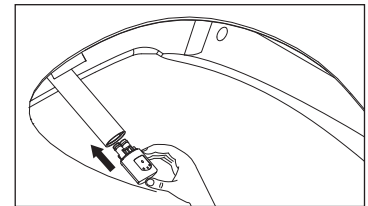

- ③ After installing the nozzle, press the stop button or press the posterior cleaning button & bidet button after 2 second, the nozzle will be automatic retraction into the machine.

WARM PROMPT

- ※ Please do not immerse or flush the product with water at the risk of electric shock or product damage.
- ※ Please do not use hydrogen chloride cleaning agent, diluent, pesticides and other non-neutral detergent to clean the product, and do not use sandpaper or rough cloth to scrub it

Common troubles and shooting

FAULT	INDICATOR	ACTION
The product wont work	Whether the power supply is on or the leakage protector is connected.	Switch the power supply is on at the circuit breaker.
No response when pressing posterior cleaning, feminine cleaning & drying buttons	No water outflow from nozzle or the water yield is very low.	Press the stop button and wait for the water supply to reactivate. Check the dual water supply is turned on inside the cistern.
	Continuous use of over 60 minutes will active saftey timer sensor	Stand up and sit down again.
	The sensor does not recognize that someone is sitting on the seat.	Sit evenly on both sides of the seat.
The nozzle actives self cleaning mode	The nozzle will stretch out to proceed self-cleaning after pressing the button of posterior cleaning or feminine cleaning.	This is a common phenomenon when the nozzle has been is use for long periodsjust need to wait for several seconds.
The nozzle stops cleaning suddenly	The nozzle stops spraying after cleaning for a period of time , then reactivates after 60 seconds	This is a safety function when the nozzlehas been is use for long periods.
The nozzle stops cleaning suddenly	If the user moves too fast or leaves the seat, the seat sensor cannot detect in a short time.	Sit back on the seat, then start the relevant function again.
Low water pressure when posterior cleaning or feminine cleaning	One of the water-inflow hose may have a poor connection and be leaking.	Check the hoses and if there is an obvious leak , call the installing plumber to correct and tighten it.
Deodorization effect is not obvious	The seat sensor not recognising somone is on the seat.	Sit evenly on both sides of the seat.
	Activated carton filter block or spacer may be blocked.	Remove the deodorizing window to clean or replace the activated carbon filter.
Deodorant function continues to work after users leaves	The deodorant function will be continue to work for 20 seconds in order to remove the residual odor after the user leaves.	No Action required.

Trouble shooting and alarm maintenance

Phenomenon	Reasons	Measures
If the power light glitters once as it lights for 2 seconds	It can be detected that inlet water temperature sensor is faulted or broken circuit	You should cut off the power supply immediately at the circuit breaker and stop using the product, then contact the local dealer or call the service hotline.
If the power light glitters twice as it lights for 2 seconds	It can be detected that outlet water temperature sensor is faulted or broken circuit	
If the power light glitters 3 times as it lights for 2 seconds	It can be detected that air temperature sensor is faulted or broken circuit	
If the power light glitters 4 times as it lights for 2 seconds	It can be detected that the seat temperature sensor is faulted or broken circuit	
If the power light glitters 7 times as it lights for 2 seconds	It can be detected that the dryer fan is faulted	

※WARNING PROMPT

If you have any trouble with your Smart Toilet that cannot be resolved using the trouble shooting guide, please contact either the your dealer, or call the national technical hotline for help.

THE MANUFACTURER RESERVES THE RIGHT TO MAKE IMPROVEMENTS AND/OR CHANGES IN DESIGNS & DIMENSIONS WITHOUT NOTICE AND WITHOUT INCURRING OBLIGATION

※WARRANTY

Argent Australia Pty Ltd ('Argent') warrants that the Smart Toilet will be free of defects in materials and workmanship (on or after the date of purchase.) 15 Years - Smart Cistern, 10 years - Ceramic, 3 Years - Smart Seat and mechanisms, 1 year - Labor, electronics and mechanism seals. Refer to warranty statement for full details.

Argent will rectify free of charge for parts and labor any fault due to a defect in materials or workmanship appearing within the applicable warranty period subject to the Warranty Conditions. Labor exclusions apply.

The benefits offered by this warranty are in addition to your rights and remedies under the Australian Consumer Law. Our goods come with guarantees that cannot be excluded under the Australian Consumer Law. You are entitled to a replacement or refund for a major failure and for compensation for any other reasonably foreseeable loss or damage. You are also entitled to have the goods repaired or replaced if the goods fail to be of acceptable quality and the failure does not amount to a major failure.

Maintenance Service Sheet

Appendix 1:

Product model		Manufacture number	
Purchased from		Purchase	
State	City	Dealer (signature):	
Repair content			
<p>Maintain regulation:</p> <ol style="list-style-type: none"> Maintenance is provided under warranty when you use the Smart Toilet in accordance with the instructions. Please contact the dealer or Technical Hotline if the fault occurs under warranty. The following situations are chargeable for maintenance under warranty: <ol style="list-style-type: none"> Faults or damages caused by the improper operation, repair or installation. Faults or damages caused by forced movement after the product is installed. Faults or damages caused by earthquakes, fires, floods, lightning strikes, corrosive liquids, abnormal voltages and other natural disasters. Faults or damages caused by other approaches which are not considered domestic use. Failure to provide the maintenance-service sheet or proof of purchase. This maintenance-service sheet is IMPORTANT, please keep safe it. 			

Appendix 2:

Client	Name			
	Address			
Product model		Manufacture		
Purchased from store		Purchase date		
Warranty period	10/15/3 – see warranty statement for full details			

Maintenance record





VERSION 2.0 Mar 2023