

## EURA DIVERTER MIXERS

### NOTES PRIOR TO INSTALLATION

1. INSPECT ALL PARTS PRIOR TO INSTALLATION FOR SUITABILITY AND/ OR DEFECTS
2. ANY SUSPECTED DEFECT SHOULD BE REPORTED AS SOON AS POSSIBLE
3. SHOULD ANY PRODUCT BE INSTALLED DESPITE A FAULT HAVING BEEN FOUND AND REPORTED, ARGENT WILL NOT ACCEPT LIABILITY FOR THE COST OF LABOUR TO REMOVE AND INSTALL ANY REPLACEMENT PRODUCT/S

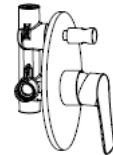

### NOTES FOR INSTALLATION

1. Please ensure pipework is clear of debris by flushing lines prior to installation of the mixer body.



### PRESSURE AND TEMPERATURE REQUIREMENTS

1. Inlet pressure range 100 – 500kpa
2. Maximum hot water temperature 60 C
3. AS/NZS 3500 requires 500 kPa maximum operating pressure at any outlet within a building
4. Hot & Cold inlets should have equalised water pressures.

Please direct any feedback for this product to Customer Central:  
support@customer-central.com.au or call  
1300 364 748

### STEP 1

- Based on the size of the body and the wall type, either secure it to the noggins or embed it into the wall at an approximate height of 1100mm. Ensure that the body is installed level, plumb and square.

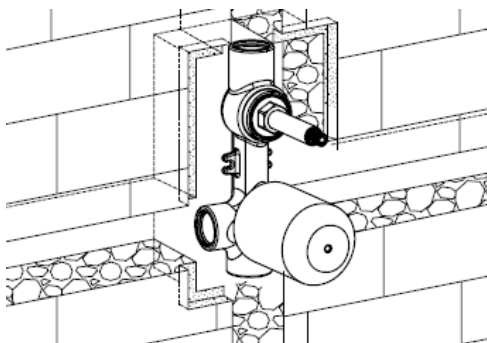

### STEP 2

- Connect the hot (LHS) and cold (RHS) supply and the mixed water pipes using applicable sealing practices. Remove the plastic tiling templates and test for water security with the mixer in both open and shut positions and the diverter open in both positions.

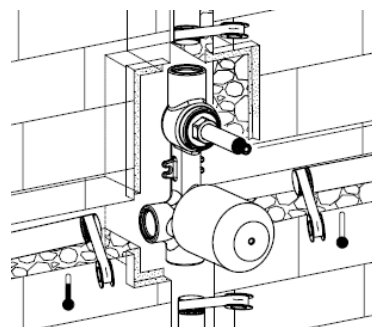

## EURA DIVERTER MIXERS

### STEP 3

- Either, sheet around the mixer body with fibre cement sheeting or backfill the exposed channels ready for tiling.

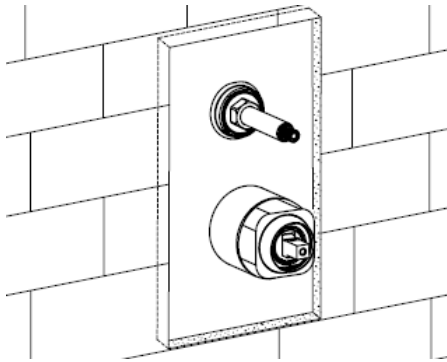

### STEP 4

- Ensure tiles are cut as close to the plastic template covering the mixer dome and diverter assembly.

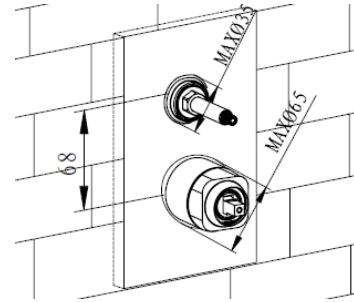

### STEP 5

- Install the trim cover plate over the dome and diverter assembly.

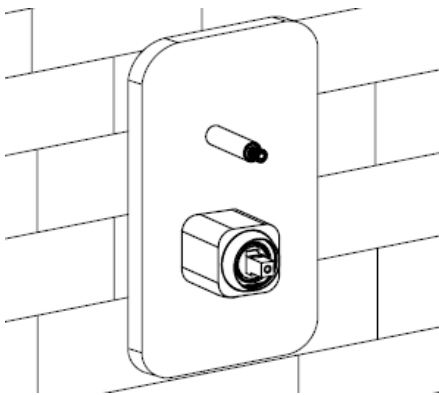

### STEP 6

- Install the lever and diverter handle securing them with the grub screws provided.

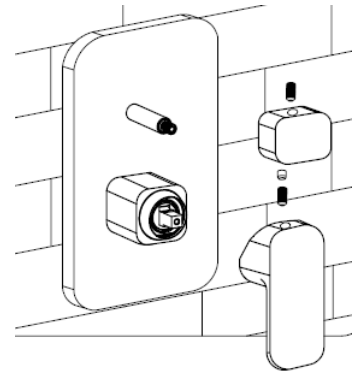

### NOTES TO THE INSTALLER

- INSPECT ALL PARTS PRIOR TO INSTALLATION FOR SUITABILITY AND/ OR DEFECTS
- SHOULD ANY PRODUCT BE INSTALLED, DESPITE A FAULT HAVING BEEN FOUND AND REPORTED, ARGENT WILL NOT ACCEPT LIABILITY FOR THE COST OF LABOUR TO REMOVE AND INSTALL ANY REPLACEMENT PRODUCT/S

### CLEANING AND MAINTENANCE

- THE SPECIAL CHROME FINISH ONLY REQUIRES CLEANING WITH MILD HOUSEHOLD DETERGENTS AND DRY WITH A CLEAN COTTON CLOTH TO RETAIN ITS LUSTROUS SHINE.
- AVOID CLEANING WITH ABRASIVE MATERIALS OR CLEANERS.