

## KITCHEN MIXERS

### NOTES PRIOR TO INSTALLATION

1. INSPECT ALL PARTS PRIOR TO INSTALLATION FOR SUITABILITY AND/ OR DEFECTS
2. ANY SUSPECTED DEFECT SHOULD BE REPORTED AS SOON AS POSSIBLE
3. SHOULD ANY PRODUCT BE INSTALLED DESPITE A FAULT HAVING BEEN FOUND AND REPORTED, ARGENT WILL NOT ACCEPT LIABILITY FOR THE COST OF LABOUR TO REMOVE AND INSTALL ANY REPLACEMENT PRODUCT/S

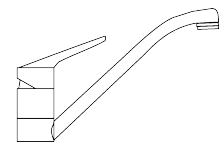

### NOTES FOR INSTALLATION

1. Please ensure pipework is clear of debris by flushing lines prior to installation.
2. We recommend hot and cold water isolation stops are used – not included in supply.
3. Mixers that feature Pull out hoses are fitted with non-return valves for backflow prevention



### PRESSURE AND TEMPERATURE REQUIREMENTS

1. Inlet pressure range 100 – 500kpa
2. Maximum hot water temperature 60 C
3. AS/NZS 3500 requires 500 kPa maximum operating pressure at any outlet within a building
4. Hot & Cold inlets should have equalised water pressures.

Please direct any feedback for this product to Customer Central:  
support@customer-central.com.au or call  
1300 364 748

### STEP 1

- Where the mixer is going into a stone or laminate top, cut a 35mm  $\varnothing$  hole.

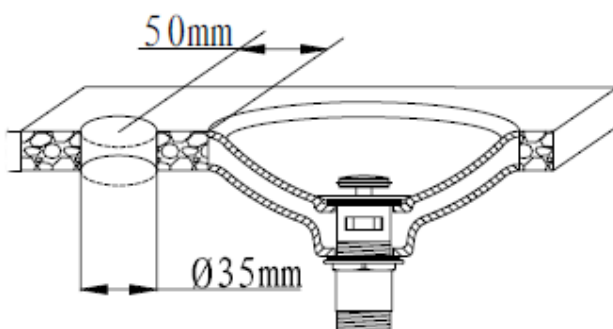

### STEP 2

- Remove the locking nut set off the mixer

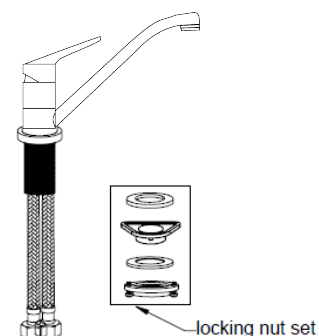

## KITCHEN MIXERS

### STEP 3

- Feed the two hoses through the hole in the sink or bench top.

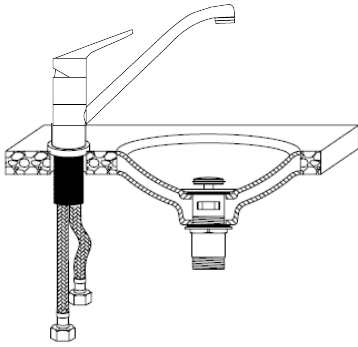

### STEP 4

- Fit the rubber gasket, holder and fixing plate assembly into position under the sink/ bench top, holder not required for solid bench tops.

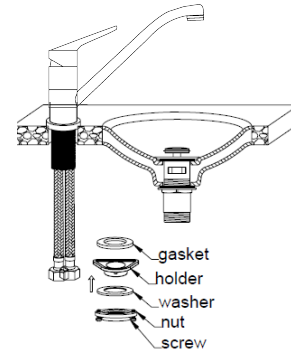

### STEP 5

- Tighten the nut assembly and then tension the screws. Make sure the hoses are connected to the correct hot and cold water feed.

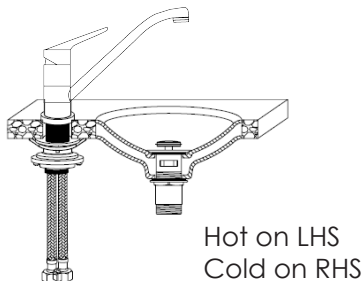

### STEP 6

- Open the stop valves, ( not included in supply) flush the lines, then close the mixer lever and check there are no leakages.

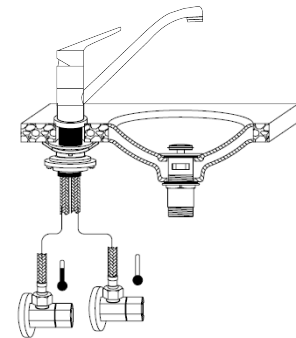

## NOTES TO THE INSTALLER

- TWISTING OR STRECHING THE FLEXIBLE HOSES DURING INSTALLATION MAY RESULT IN FAILURE, AND WILL VOID THE WARRANTY.
- AVOID SEVERE BENDS IN THE FLEXIBLE HOSES AS THIS MAY RESULT IN FAILURE AND WILL VOID THE WARRANTY.

## CLEANING AND MAINTENANCE

- THE SPECIAL CHROME FINISH ONLY REQUIRES CLEANING WITH MILD HOUSEHOLD DETERGENT AND DRY WITH A CLEAN COTTON CLOTH TO RETAIN ITS LUSTROUS SHINE.
- AVOID CLEANING WITH ABRASIVE MATERIALS OR CLEANERS.